

**Unilumin**

LED SOLAR LIGHTING

# Essential I SERIES

**Unilumin**

TOGETHER, FOR A BRIGHTER FUTURE



UNILUMIN GROUP CO., LTD

HQ Address: 112 Yongfu Rd., Qiaotou Village, Fuyong Town, Baoan District, Shenzhen 518103 China

Manufacturing Base: Unilumin Industrial Park, 6 North Lanjing Road Pingshan District, Shenzhen, China

TEL: +86-0755-29918999 | FAX: +86-0755-29912092 | E-mail: ledlighting@unilumin.com

[www.unilumin.com](http://www.unilumin.com) | [www.unilumin-lighting.com](http://www.unilumin-lighting.com)

The product designs and specifications are subject to change without prior notice.  
All rights reserved, copy is prohibited without the permission of Unilumin Group Co., Ltd.

## Essential I (All in one)

Incorporating a seamless design that harmoniously integrates solar panels, LED lights, and batteries, our Essential I Series all-in-one solar street light offers a hassle-free installation and maintenance experience. This innovative solution provides reliable and sustainable lighting, effectively reducing energy consumption and carbon footprint, while enhancing safety and visibility in urban environments.

### Features

- High-strength aluminum alloy construction, robust and reliable
- Uniform light output with professional PC optical lenses
- High-quality LEDs with up to 160lm/W luminous efficacy
- LiFePO4 battery for longer service life, safety, and stability
- Intelligent charge and discharge management
- Compatible with sensor for more flexible working mode

### Applications

Park, parking lot, pedestrian path, urban & residential streets, etc.

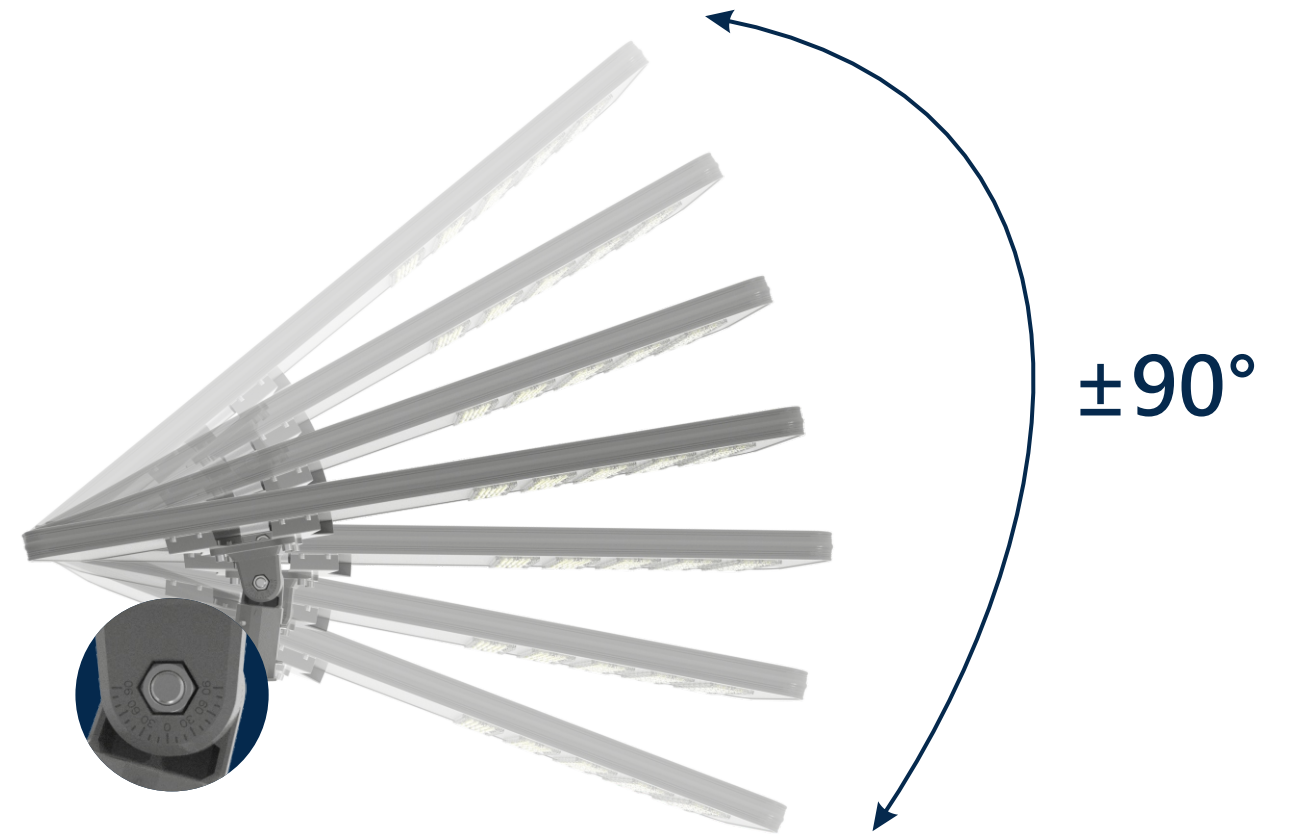

$\pm 90^\circ$  Mounting angle adjustable

## Dimension

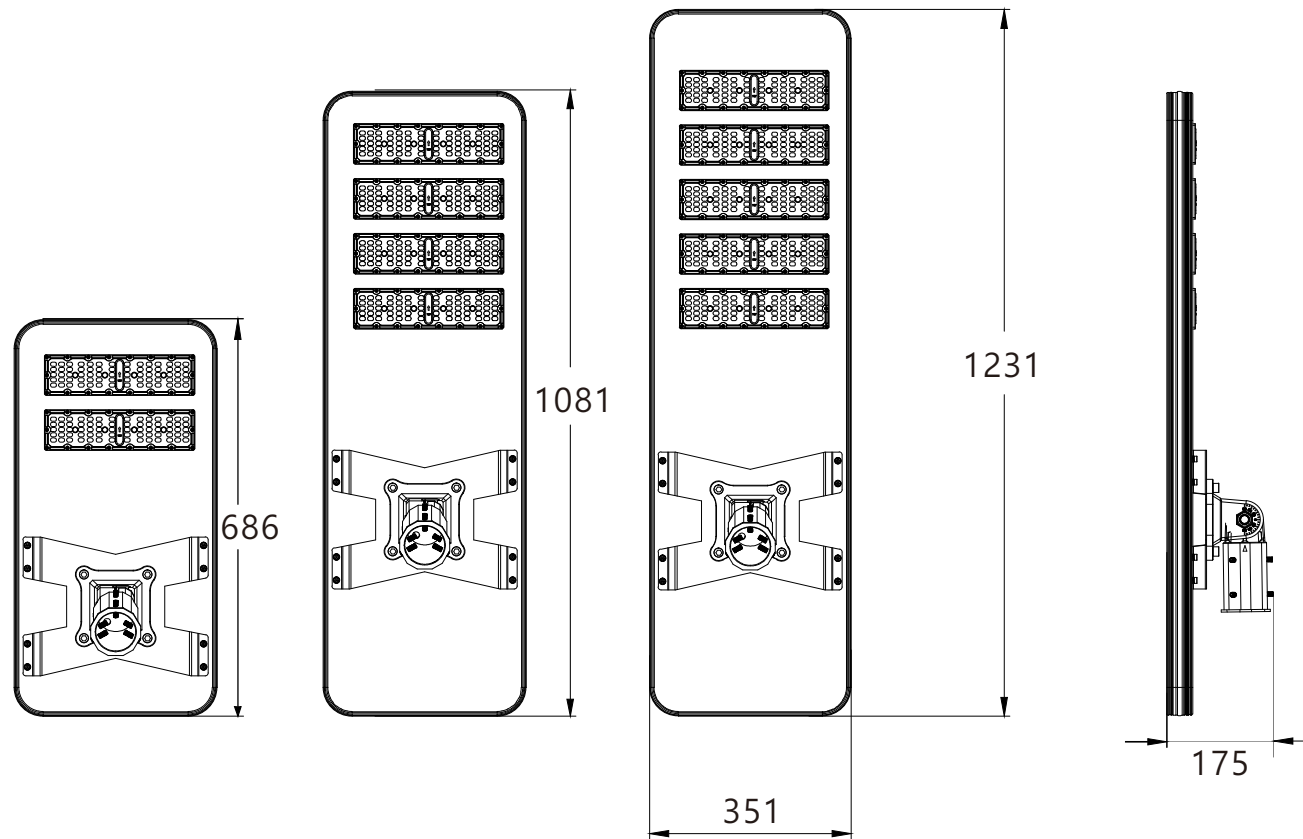

## Light Distribution

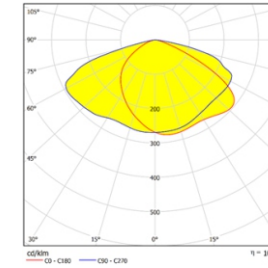

Type II

## Parameters

Product Model	UNI-SLEO-02000	UNI-SLEO-03000	UNI-SLEO-04500
Luminous Flux( lm)	2000	3000	4500
System Voltage	3.2V		
System Power (W)	12.5	19	30
Monocrystalline Solar Panel	25W/5V	40W/5V	80W/6V
LiFePO4 Battery	3.2V/20AH	3.2V/30AH	3.2V/60AH
Control Mode	Remote control/Timer dimming/Photocontrol/Intelligent power reduction		
LED Life Time	> 50,000 Hrs ( L70@Ta=25°C )		
Luminaire Efficacy (Tq=25°C)	150lm/W~160lm/W		
Default Lighting Mode*	1H100%+2H60%+2H30%+7H15%		
Overcast Days	365 days lights (4-5 hours of sunlight)		
CCT(±300K)	3000K/4000K/5000K/5700K/6500K		
CRI	≥70		
Housing Materials	Aluminum Housing + Extruded Aluminum Frame + PC		
IP/IK	IP65 / IK08 (solar panel IK07)		
Insulation Class	Class III		
Spigot Diameter ( mm )	Φ60		
Installation Height (m)	4-6		
Luminaire Dimension (mm)	686x351x175	1081x351x175	1231x351x175
Luminaire Packing Dimension (mm)	805x370x125	1100x370x125	1285x370x125
Net Weight (±0.2kg)	7.6	10.0	12.0
Gross Weight (±0.2kg)	8.9	11.4	13.5

\*Factory default value, the lighting mode can be customized as per specific requirements.

## Essential I (All in two)

Essential I series all-in-two solar street light combines flexibility and performance. With separate solar panels and light fixtures, it offers versatile installation options and optimal sunlight absorption. Featuring intelligent power management and a durable design, it ensures consistent operation in challenging weather conditions, providing efficient and visually appealing lighting for your outdoor spaces.

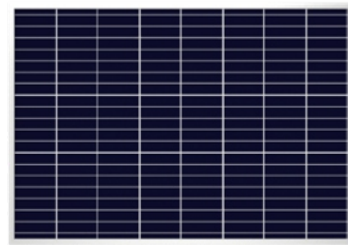
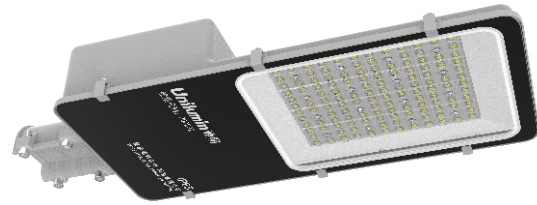

### Features

- High-strength aluminum alloy construction, robust and reliable
- Uniform light output with professional PC optical lenses
- High-quality LEDs with up to 160lm/W luminous efficacy
- LiFePO4 battery for longer service life, safety, and stability
- Intelligent charge and discharge management
- Optional sensor for more flexible working modes

### Applications

Park, parking lot, pedestrian path, urban & residential streets, etc.

## Various Installation Methods

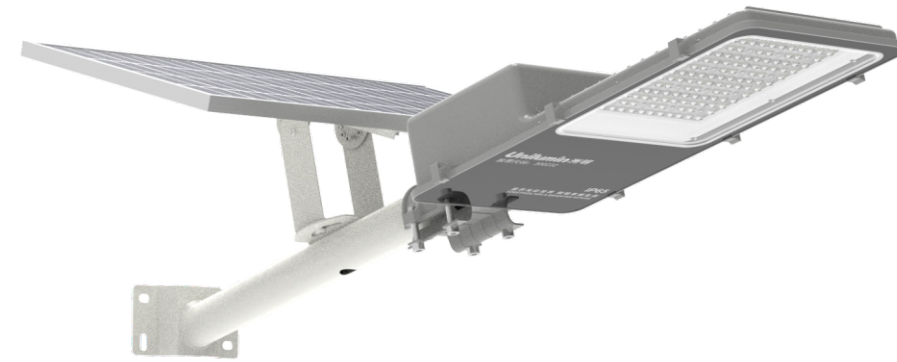

Mast arm



On the post

## Dimension

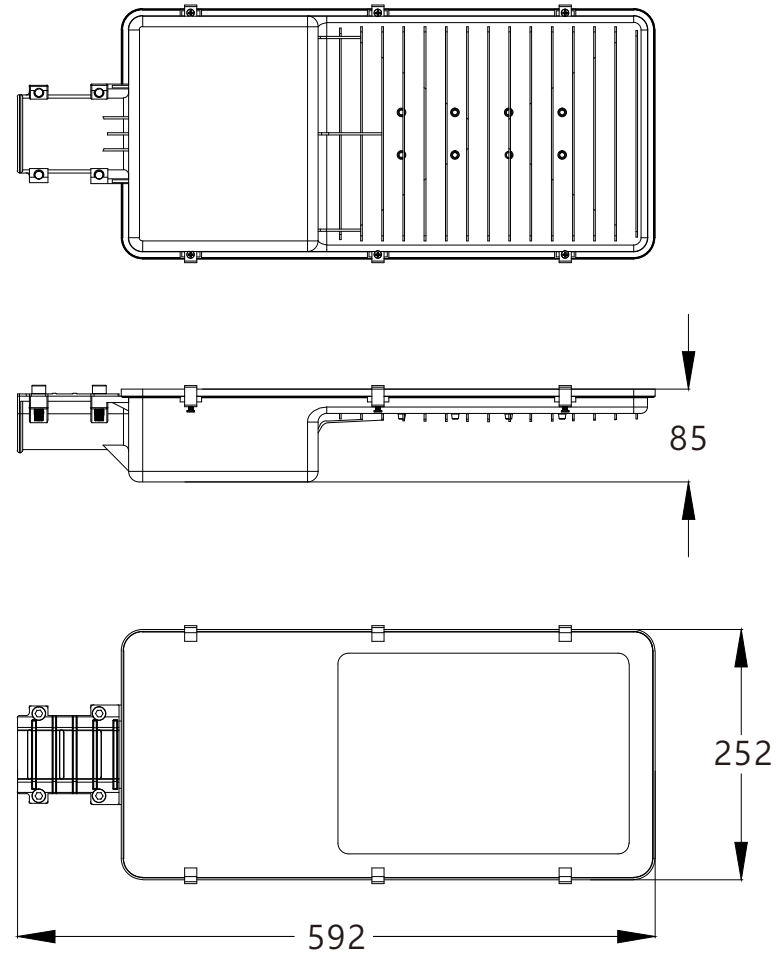

## Light Distribution

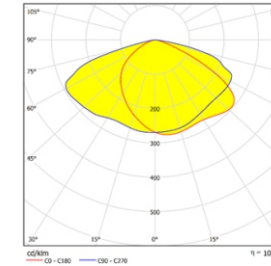

Type II

## Parameters

Product Model	UNI-SLEN-01500	UNI-SLEN-02000	UNI-SLEN-03000	UNI-SLEN-04500	UNI-SLEN-08000
System Voltage	3.2V	3.2V	3.2V	3.2V	12.8V
Solar Panel	20W/5V	25W/5V	40W/5V	80W/6V	100W/18V
LiFePO4 Battery	3.2V/15AH	3.2V/20AH	3.2V/30AH	3.2V/60AH	12.8V/24AH
Control Mode	Timer dimming/Photocontrol/Intelligent power reduction				
LED Life Time	>50,000 Hrs (L70@Ta=25°C)				
Luminaire Efficacy (Tq=25°C)	160lm/W	160lm/W	160lm/W	140lm/W	140lm/W
Luminous Flux( lm)	1500	2000	3000	4500	8000
Default Lighting Mode*	1H100%+2H60%+2H30%+7H15%				
Overcast Days	365 days lights (4-5 hours of sunlight)				
CCT(±300K)	3000K/4000K/5000K/5700K/6500K				
CRI	≥70				
Housing Materials	Aluminum Housing				
IP	IP65				
Insulation Class	ClassIII				
Spigot Diameter(mm)	Φ60				
Installation Height(m)	4-6	4-6	4-6	4-6	6-8
Luminaire Dimension(mm)	592*252*85mm				
Solar Panel Dimension(mm)	350*460*15	350*520*15	670*425*25	670*820*30	670*1000*30
Luminaire Packing Dimension(mm)	630*555*210 (4PCS)	630*555*210 (4PCS)	630*555*210 (4PCS)	630*555*210 (4PCS)	630*555*210 (4PCS)
Solar Panel Packing Dimension(mm)	370*480*160	370*540*160	690*440*160	690*840*160	690*1020*130
Luminaire Net Weight(kg±0.3)	2.76	3.03	3.12	3.9	5.3
Solar Panel Net Weight(kg±0.2)	1.02	1.17	1.92	4.72	5.81
Gross Weight(kg±0.5)	3.98	4.6	5.64	9.42	12.11

\*Factory default value, the lighting mode can be customized as per specific requirements.

## Essential I (Floodlight)

Essential I series solar flood light is designed with an adjustable feature that allows users to direct the light precisely and highlight signage or landscapes. It has independent solar panels and an advanced battery, ensuring reliable and long-lasting performance. Use this versatile and powerful flood light to enhance security, create captivating visuals, and draw attention to focal points in outdoor spaces.

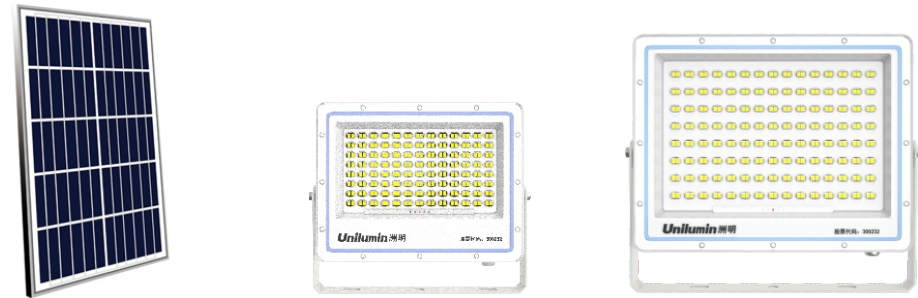

### Features

- High-strength aluminum alloy construction, robust and reliable
- Uniform light output with professional PC optical lenses
- High-quality LEDs with up to 160lm/W luminous efficacy
- LiFePO4 battery for longer service life, safety, and stability
- Stylish and compact design
- Mounting angle adjustable

### Applications

Signage, billboard, park, stadium, parking lot, etc.

## Installation Guidance

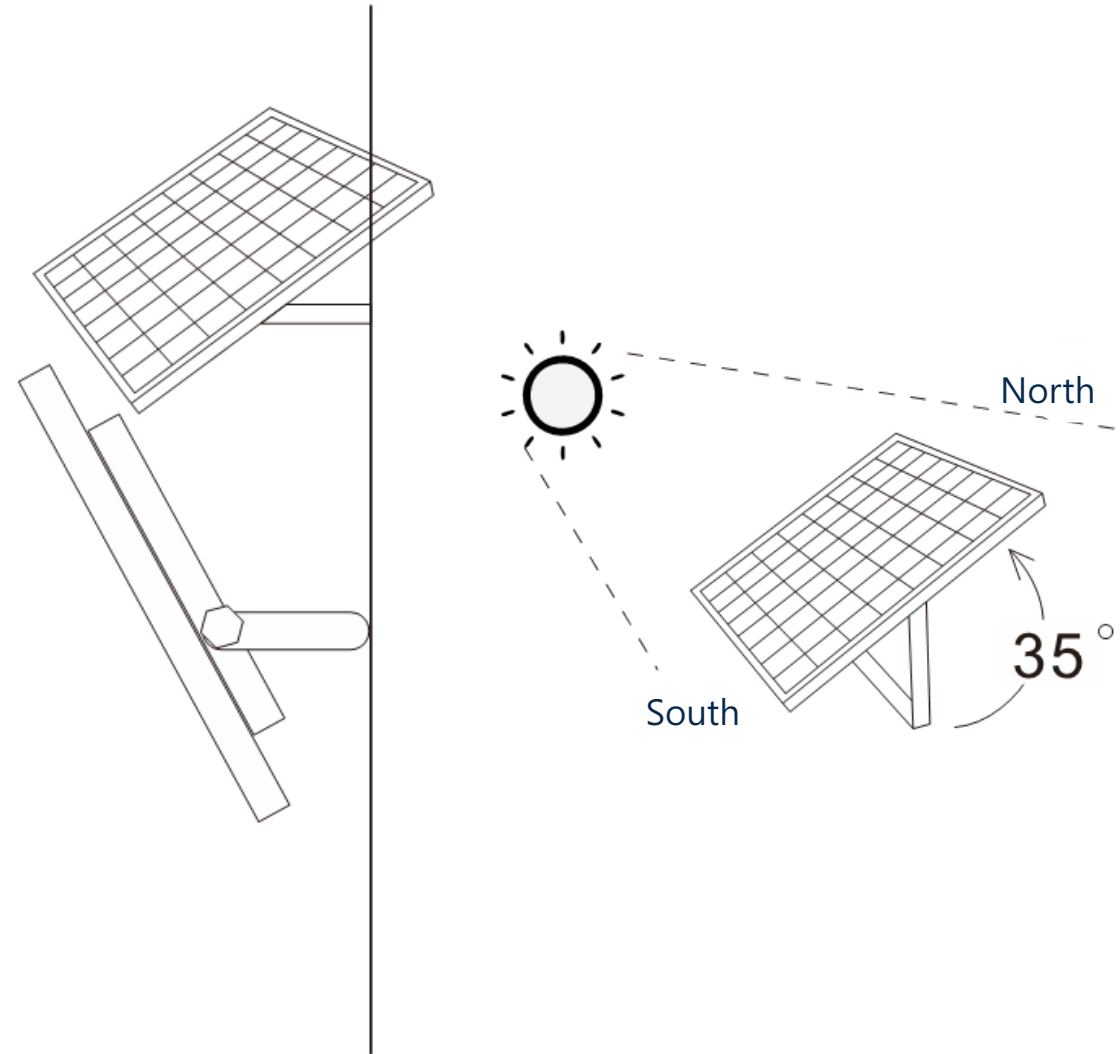

## Dimension

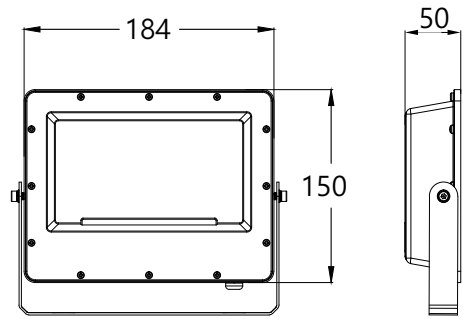

UNI-PLE2-01500

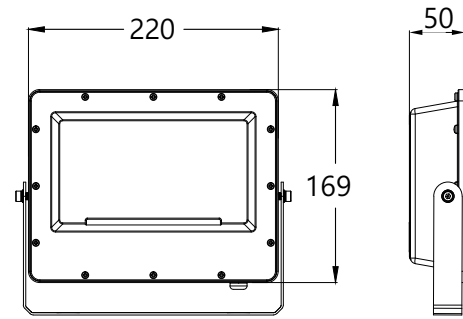

UNI-PLE2-02000

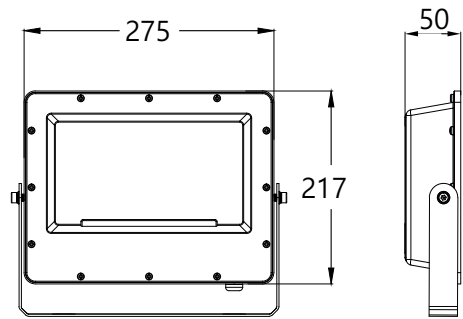

UNI-PLE2-03000

## Light Distribution

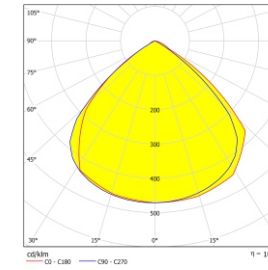

Type I

## Parameters

Product Model	UNI-PLE2-01500	UNI-PLE2-02000	UNI-PLE2-03000
System Voltage	3.2V		
Solar Panel	20W/5V	25W/5V	40W/5V
LiFePO4 Battery	3.2V/15AH	3.2V/20AH	3.2V/30AH
Control Mode	Remote control/Timer dimming/Photocontrol/Intelligent power reduction		
LED Life Time	>50,000 Hrs (L70@Ta=25°C)		
Luminaire Efficacy (Tq=25°C)	160lm/W		
Luminous Flux( lm)	1500	2000	3000
Default Lighting Mode*	1H100%+2H60%+2H30%+7H15%		
Overcast Days	365 days lights (4-5 hours of sunlight)		
CCT(±300K)	3000K/4000K/5000K/5700K/6500K		
CRI	≥70		
Light Distribution	90°		
Mounting Options	Bracket installation		
Housing Material	Aluminum Housing		
IP	IP65		
Insulation Class	Class III		
Installation Height ( m)	0~6		
Luminaire Dimension ( mm)	184x150x50	220x169x50	275x217x50
Solar Panel Dimension ( mm)	350x460x15	350x520x15	670x425x25
Packing Dimension ( mm)	493x375x230(4PCS)	555x375x230(4PCS)	700x500x260(4PCS)
Luminaire Net Weight ( kg±0.3)	0.76	1.1	1.54
Solar Panel Net Weight ( kg±0.2)	1.02	1.17	1.92
Gross Weight ( kg±0.5)	2.18	3.07	4.7

\*Factory default value, the lighting mode can be customized as per specific requirements.

## Working Mode

1H-100% brightness, 2H-60% brightness, 2H-30% and 7H-15% brightness, with intelligent management for extended runtime

Summer and autumn: With longer peak sunlight hours (4.5 PSH), the solar panel can be provided with enough sunlight for battery charging, taking 6–8 hours to 100% charge in 14-hour daylight, ensuring nighttime lighting.

When the peak sunshine hours are enough ( $\geq 3.5$ PSH)

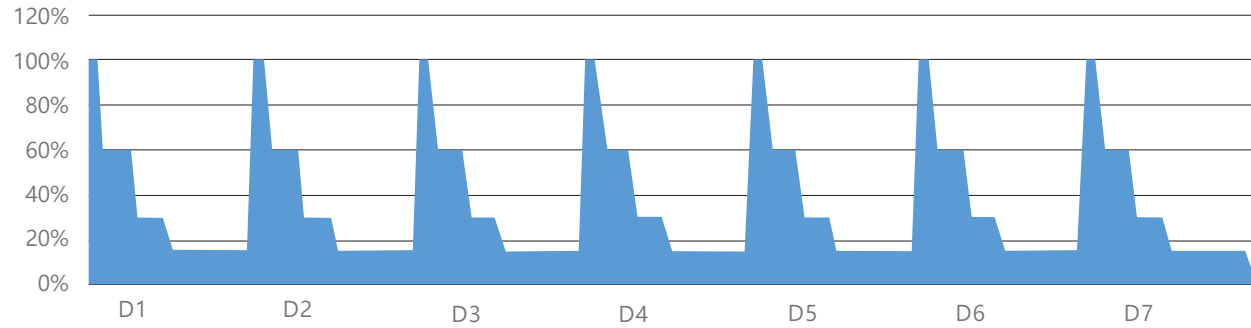

Spring and winter : Limited peak sunlight hours (3.1PSH) and extended periods of overcast or rainy days result in insufficient solar radiation (peak sunlight  $\leq 2.0$  PSH) to fully charge the battery for the standard operating mode, The management system will automatically reduce the brightness according to the battery capacity to ensure the most basic lighting function; this will continue until the weather improves.

When the peak sunshine hours are not enough ( $\leq 2.5$ PSH)

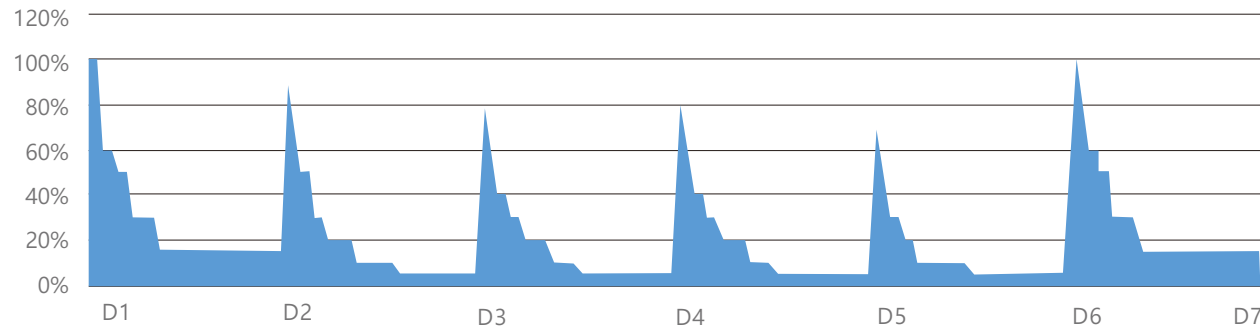

## Control Guidance

